

PITTS 30CC V2

ASSEMBLY MANUAL



INTRODUCTION

Dear Customer:

Thanks for purchasing this newly designed PITTS 30CC aerobatic RC airplane. This plane's weight is about 10Lbs. It's good for imac and free flight. It's a beautiful plane with amazing flight performance. It's covered with genuine monocoque, and comes with good quality accessories, including carbon fiber wing tube, carbon fiber or Anodized 6061 Aluminum landing gear as an option. We hope you like this plane.

A QUICK WORD ABOUT SAFETY AND RADIO CONTROL FLYING MODELS

With radio control aircraft, like any hobby or sport, there are certain risks. The operator of these models is responsible for these risks. If misused or abused, you may cause serious bodily injury and/or damage to property. With this in mind, you will want to be certain that you build your model carefully and correctly. If you are not an experienced flier, have your work checked and ask for help in learning to fly safely. **This model aircraft is not a toy** and must be operated and flown in a safe manner at all times. Always perform a pre-flight check of the model including all control surfaces, proper function of the radio gear, structure, radio range, and any other area relating to the safe operation of this aircraft.

Models are not insurable but operators are. You can obtain coverage through membership in the Academy of Model Aeronautics (AMA). For an AMA information package call 1-800-435-9262, ext. 292 or visit the AMA website at "www.modelaircraft.org".

***By the act of using the final assembled model,
the purchaser/operator accepts all resulting liability.***

ARF MODELS WARRANTY AND RETURN POLICY

We guarantee that the plane is in perfect condition at purchase. The warranty will be voided after modifications and usages. If you have any questions or find any issues, please contact the distributors in your area. For US customers, please contact General Hobby. Their website is www.generalhobby.com. Their phone number is 909-581-8873. Customers in other areas please contact the sellers you purchased it from.

SPECIFICATIONS

Wing Span: 61"(1550mm)

Length: 63"(1600mm)

Wing Area: 1327sq in(85. 6sq .dm.)

Flying Weight: 9.5-10.8lbs(4300-4900g)

Electric Power: A50 or A60 OUTRUNNER(1800-2000Watt electric)

PROP: 18x8E-20x10E LI-POLY 6-8S 3300-5800mAh

ESC 80-100A

Engine Power: .90-.120 (2C) . 110-. 120 (4C) 26-35CC Gas

Radio: 4-6CH/6-7S

Features:

01. Newly designed structure
02. Two pieces removable wings
03. PVC canopy
04. Carbon fiber wing tube
05. Larger aileron and elevator design for excellent 3D aerobatic flying.



06. Anodized aluminum Long servo arms included.
07. Servo extension safety connector clips.



08. High performance cap head screws.



09. Flat nylon hinges for better flying strength.

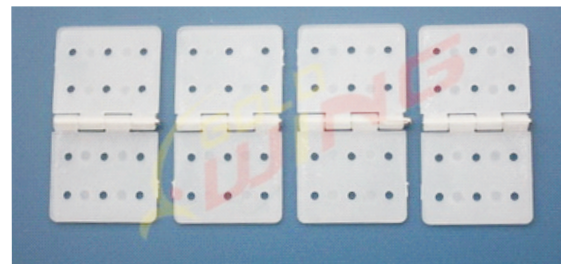

10.High quality ball link assemblys.



11.Dual Fiberglass horn assembly.

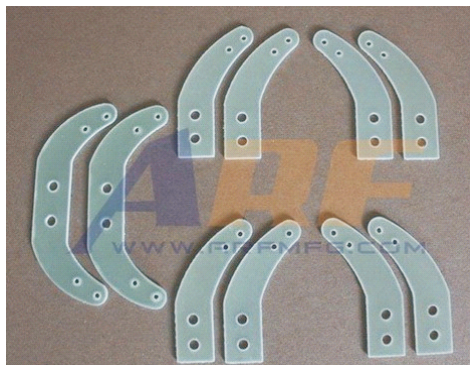

12. Carbon fiber tail wheel assembly.



13.High-quality durable rubber wheels.

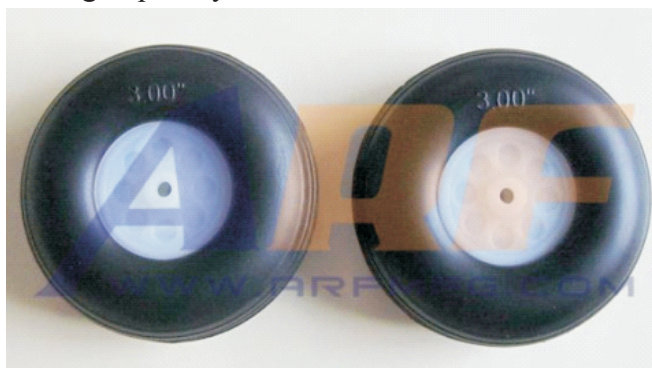

14. Two options for landing gear: Anodized 6061 Aluminum or Carbon fiber.
Anodized 6061 Aluminum landing gear. Carbon fiber landing gear.



15.Canopy quick release mechanism.



TABLE OF CONTENTS

Introduction	01
Features	02
Wing Assembly	05
Aileron Control Horns	05
Aileron Servo Installation	06
Elevator Assembly	08
Stab and Elevator Installation	09
Elevator Servo Installation	11
Rudder Assembly	12
Rudder Horns and Hinges	13
Rudder Servo Installation	14
Tail Wheel Installation	16
Fin And Stab Cable Tensioning	18
Main Landing Gear Installation	19
Landing Gear Installation	19
Pants Installation	20
Engine Installation	20
Firewall Holes Assembly	21
Throttle Servo Installtion	22
Fuel Tank and Fuel Line assembly	23
Ignition Module and Battery assembly	24
Cowling Installation	25
Wing Final Assembly	27
Canopy assembly	28
Flight Preparation	29
C.G Location.....	29
Symmetry Control	29
Control Throws	30
Engine Debugging	30
Flight Checking.....	30

Wing Assembly

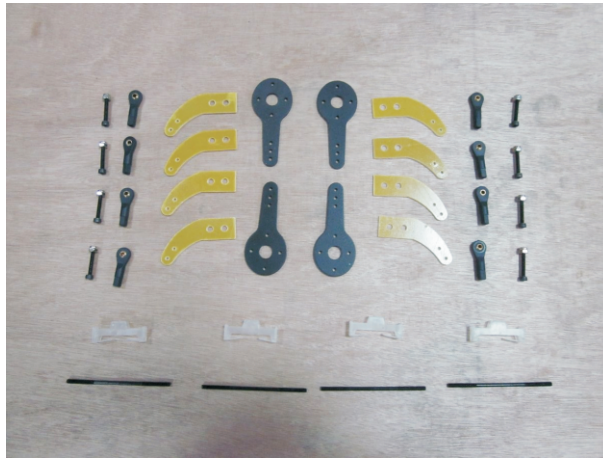

Aileron Control Horns

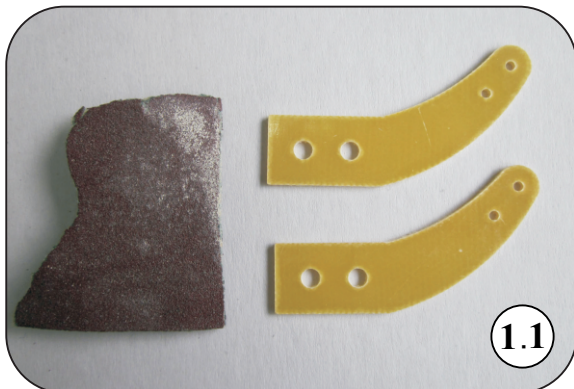

1. Scuff the horns with sand paper to ensure a good glue bond. Drill 2.5mm holes in the horns and install the M2.5mm ball link with the screw.



2. Pre-hinged control surface is ready to fly. Remove the covering below to expose the pre-cut slots with a knife.



3. Apply 30 minute epoxy inside the pre-cut slots and coat the horns with epoxy. Insert them into the pre-cut slots. Wipe away excess glue with rubbing alcohol.

Aileron Servo Installation

Minimum Required Servo: 180 in.oz / Metal Gear / Digital

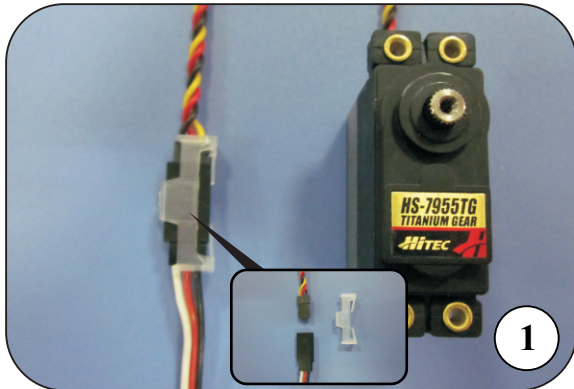

1. Use the provided safety clips to secure the servo and servo extension leads.

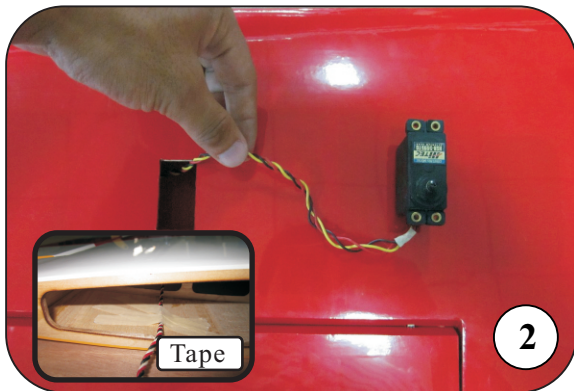

2. The covering of the servo location had been removed as shown. Put the end of the servo extension in the servo location. And then pull the extension lead through to the root of the wing. Taping servo lead to the inside of the wing panel will help to prevent lead from dropping back inside of wing panel during transportation.

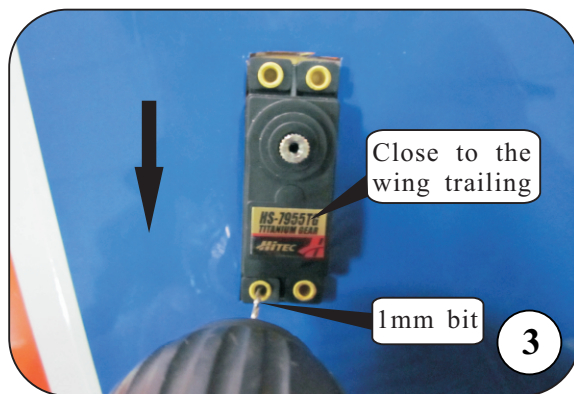

3. Drill 1mm holes for the servo mounting screws. Position the servo with the servo label closest to the wing trailing edge.



4. Use a drop of thick CA glue on each screw to prevent tapping screws from loosening due to vibration. Install servo with M2*12mm tapping screws.



5. Mount the servo arm and the extension arm with M2*8mm screws and locking nuts as shown. Then turn on the transmitter and plug the servo into receiver. Ensure the channel is neutral. Install the servo arm facing toward the wing tip. Position the servo arm 90 degrees to the servo.

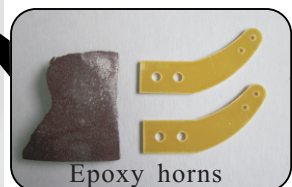
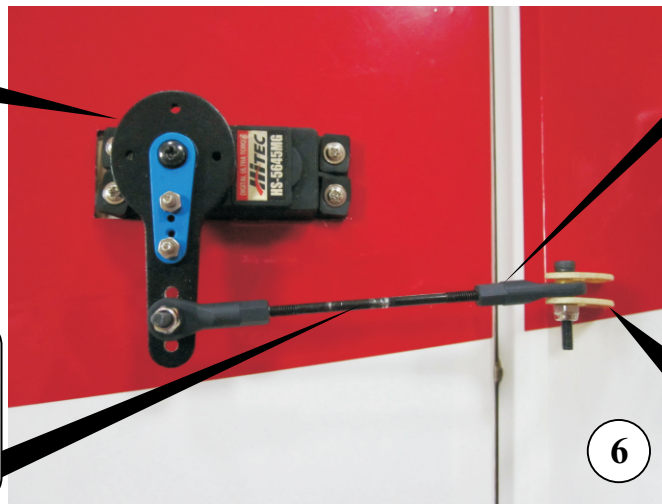
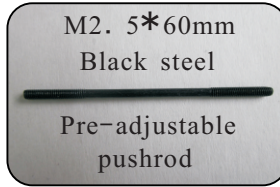
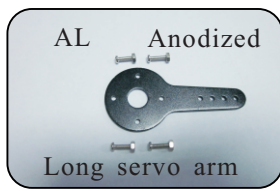

6. Adjust the pushrod length till the aileron and servo are in the neutral position. And then install the pushrod to the arm with M2. 5*16mm hex socket screw and lock nut.

Repeat all the previous steps for the other wing.

Upper Wing Installation

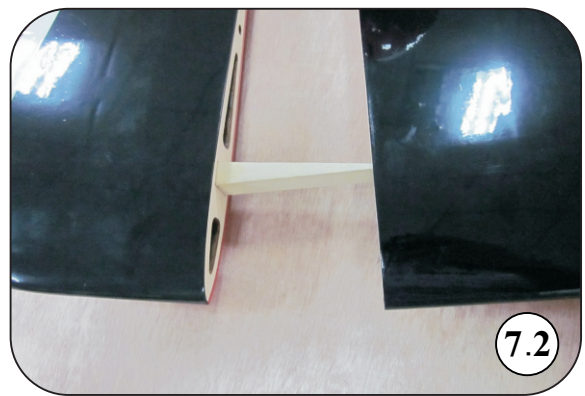

7. Apply 30 minute epoxy inside the wing pre-cut slot and coat the wing batten with epoxy, Insert the batten into the pre-cut slots.

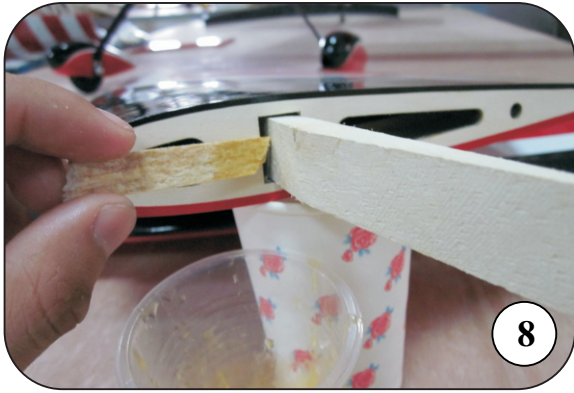

8. Apply 30 minute epoxy inside the other wing pre-cut slot and coat the wing batten with epoxy, Insert it into the pre-cut slot.

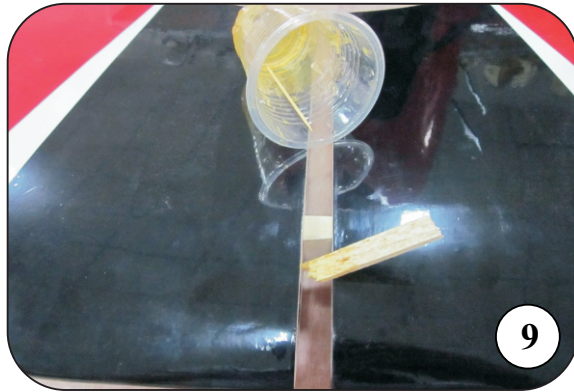

9. Coat the wing rib with epoxy, put the wing together. Wipe away excess glue with rubbing alcohol.



10. Stick them with the tape till the epoxy dry.

Elevator Assembly

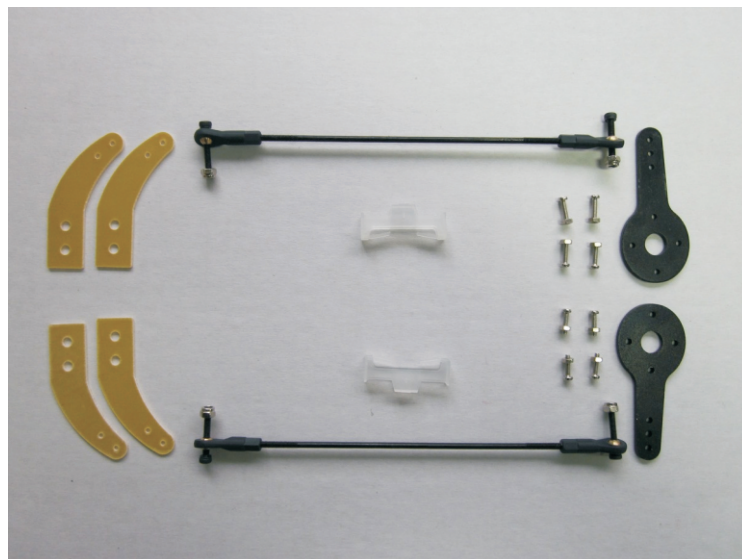

Stab and Elevator Installtion



1. Insert the stab into the fuselage tail. Measure the stab to find the middle.



2. Mark the stab with a pen when the stab is symmetrical. Trace around the fuselage with a knife and remove the covering below to expose the board. Take care not to scratch the board.



3. Coat the horns with epoxy. Insert them into the fuselage again. Make sure the stab is symmetrical.

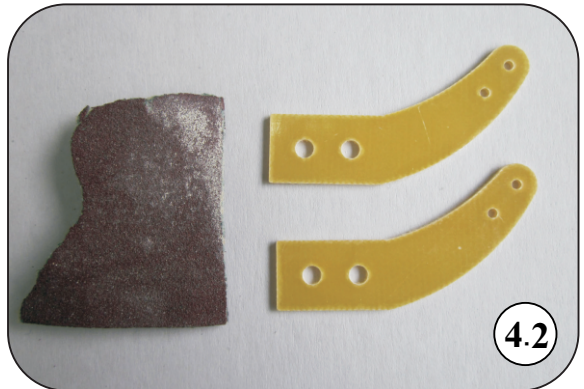
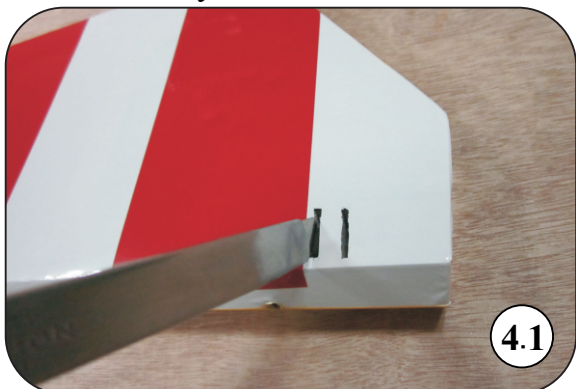

4. Remove the covering below to expose the pre-cut slots with a knife. Scuff the horns with sand paper to ensure a good glue bond.

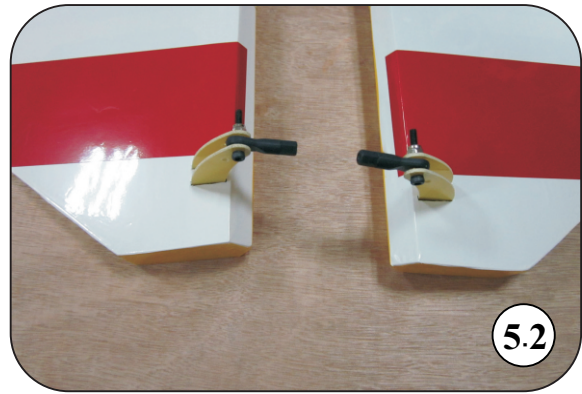
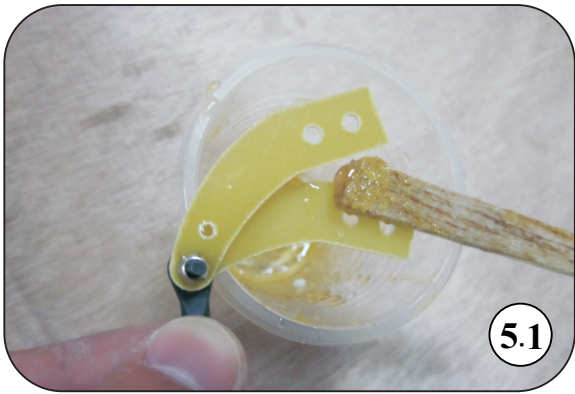

5. Install the two horns with M3*16mm screw and locking nut. Apply 30 minute epoxy inside the pre-cut slots and coat the horns with epoxy, Insert them into the pre-cut slots.

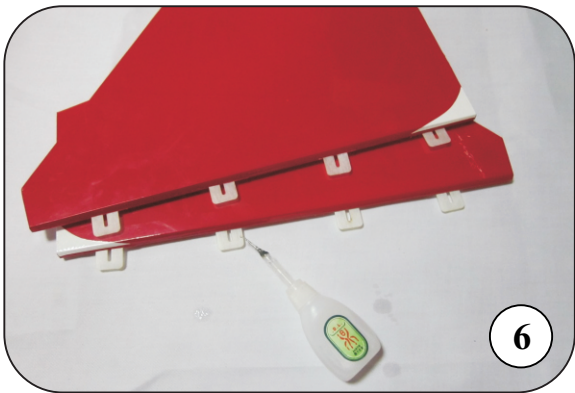

6. Insert the hinge into the elevator hinge-holes. Stick the hinge to the elevator first.



7. Insert the hinge into the stab hinge-holes. Use a drop of thick CA glue to stick the stab and elevator.

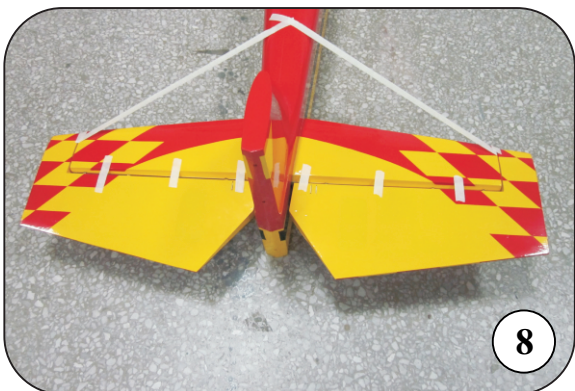

8. Check you have full elevator deflection before fasten the stab with tape.

Elevator Servo Installation

Minimum Required Servo: 180 in.oz / Metal Gear / Digital



1. Remove the covering below to expose the pre-cut servo hole with a knife. Use the provided safety clips to secure the servo and servo extension leads.

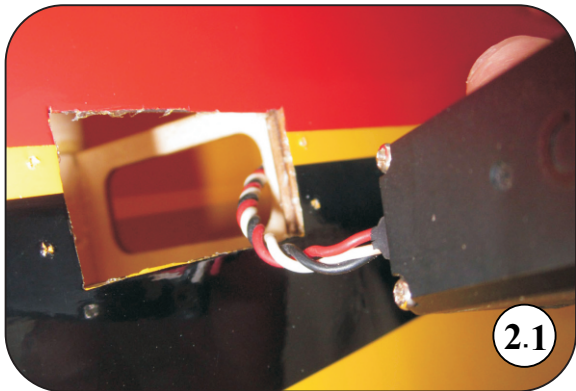

2. Run the extension lead through the fuselage to the receiver. Taping servo lead to the fuselage will help to prevent lead from dropping back inside of wing panel during flying.



3. Position the servo with the servo label toward the fuselage head. Drill 1mm holes for the servo mounting screws using the long aiguille.



4. Install servo with M2*12mm servo mounting screws. Use a drop of thick CA glue on each screw to prevent screws from loosening due to vibration.

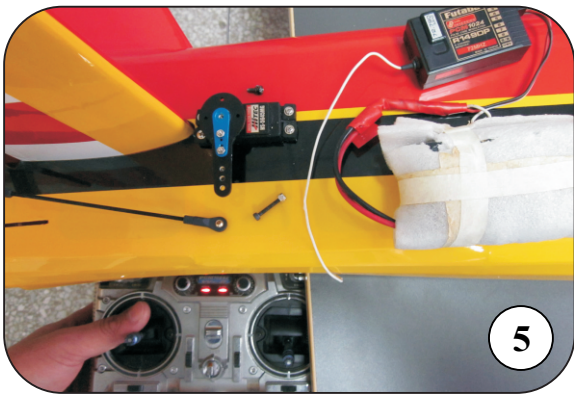

5. Turn on the transmitter. Make sure the servo is in the neutral position. Install the servo arm. Position the servo arm 90 degrees to the servo, and tighten the arm screw.

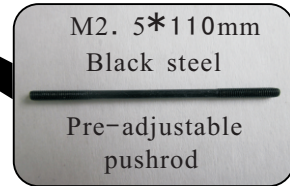
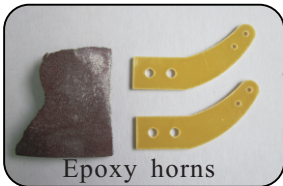
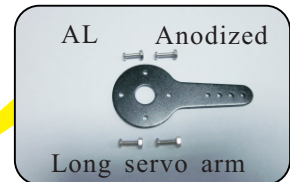
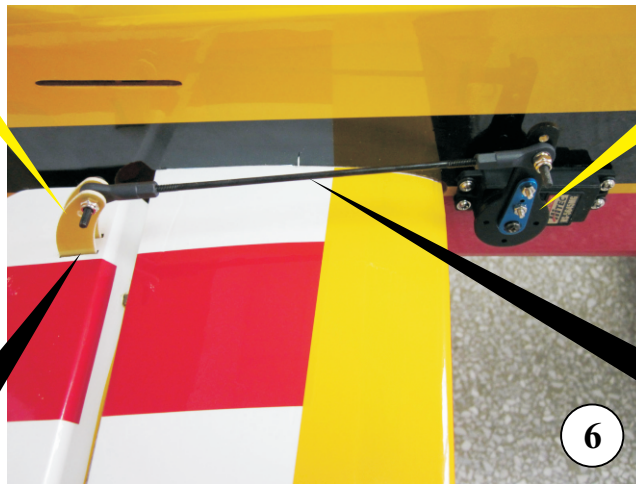

6. Adjust the pushrod length so that the servo and elevator are both in the neutral position. Install the arm pushrod with M3*16mm screw and lock nut.

7. Repeat all the previous steps for the other elevator.

Rudder Assembly

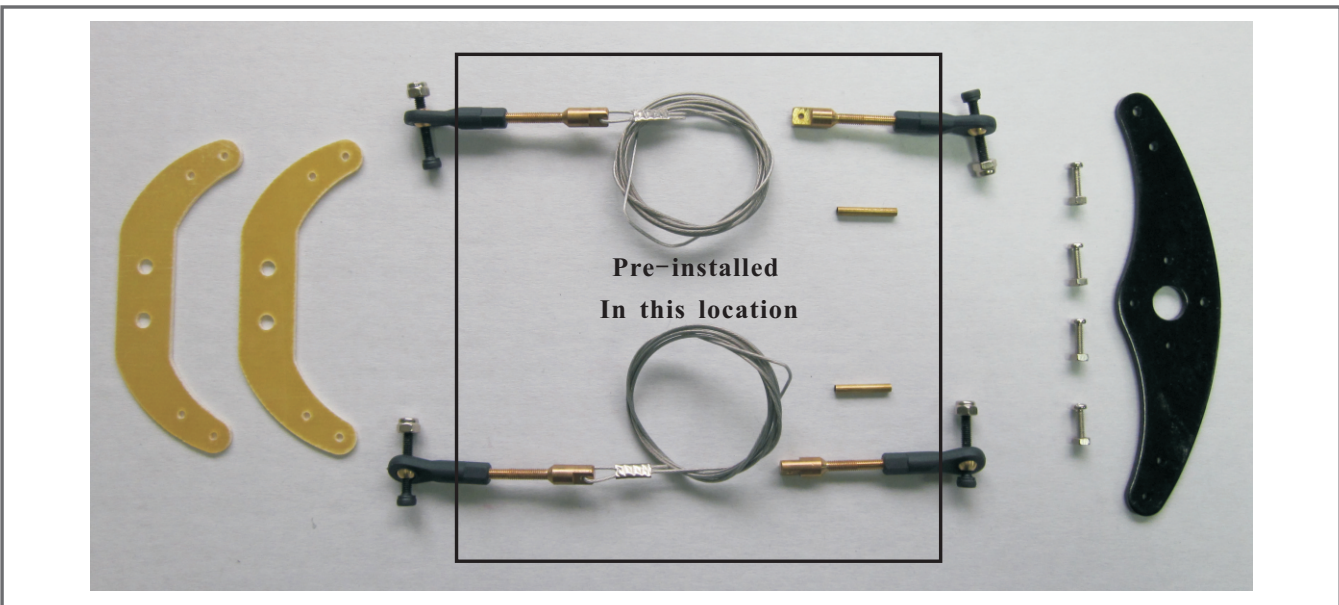

Rudder Horns and Hinges



1. Trace around the fuselage with a knife and remove the covering below to expose the board. Take care not to scratch the board.



2. Remove the covering below to expose the pre-cut slots with a knife.

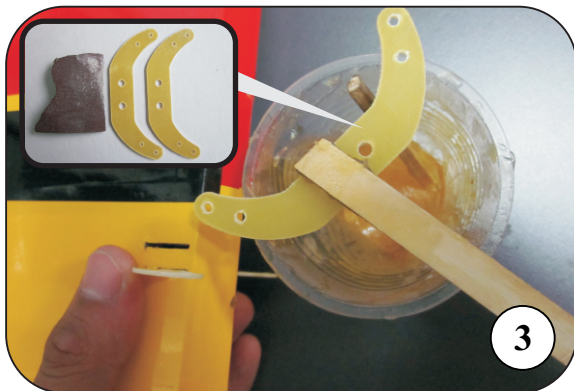

3. Scuff the middle of horns with sand paper to ensure a good glue bond. Apply 30 minute epoxy inside the pre-cut slots. Coat the horns with epoxy. Insert them into the pre-cut slots.

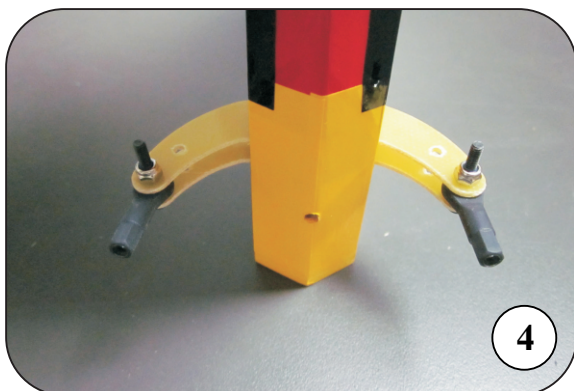

4. Install the ball link with M2.5*16mm screws and locking nuts. Tightening the nuts is recommended. Wipe away excess glue with rubbing alcohol. Make sure the horns are correctly aligned and symmetry before the epoxy has cured.

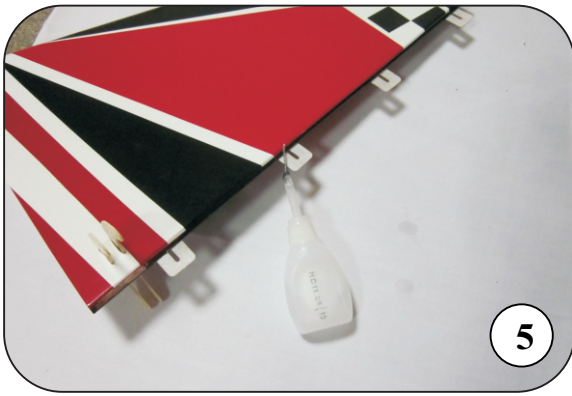

5. Insert the hinge into the rudder hinge-holes. Stick the hinge to the rudder first.



6. Insert the hinge into the hinge-holes. Use a drop of thick CA glue to stick the stab and elevator.

Rudder Servo Installation

Minimum Required Servo: 180 in.oz / Metal Gear / Digital

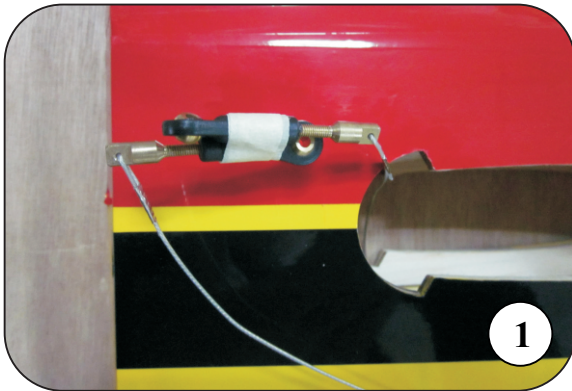

1. The rudder cables and couplers have been pre-installed.

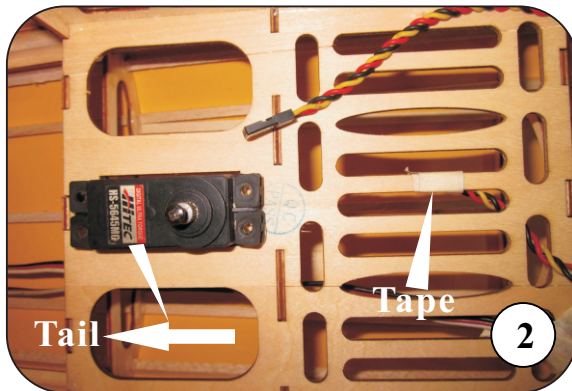

2. Position the servo with the servo label toward the fuselage tail. Fasten the servo wire with the tape.

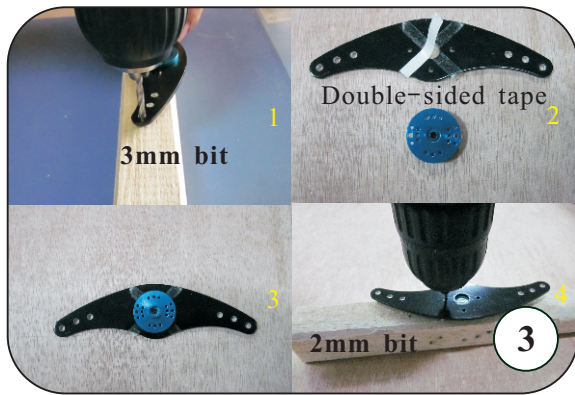

3. Drill 2.5mm holes in the AL long arm for installing 2.5mm ball links and screws. Drill 2mm holes in the servo arm and mount it with M2*8mm screws and nuts.



4. Drill 1mm holes. Install the servo with the M2*12mm tapping screws.

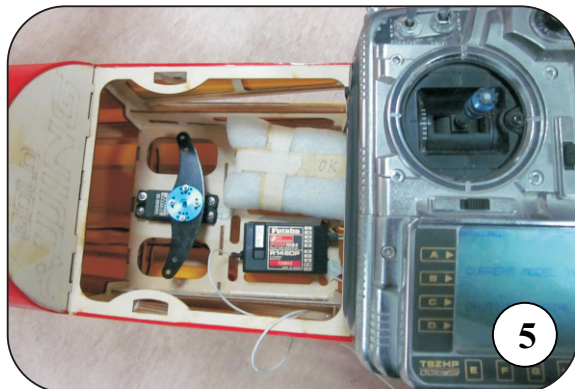

5. Turn on the transmitter. And then install AL long arm on the servo. position the servo arm 90 degrees to the servo.

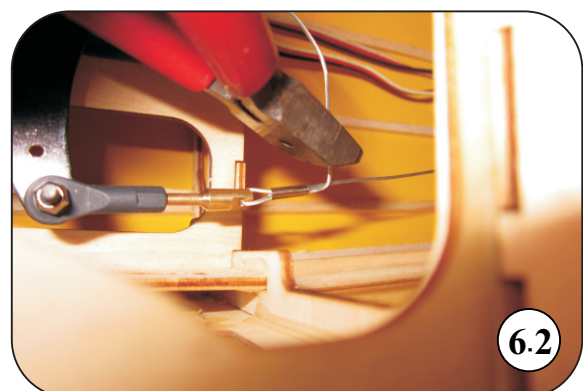

6. Mount the pre-installed ball link to the servo arm with the M2.5*16mm screws and the locking nuts. Remove any slack in the cables and crimp to secure. Crimp the brass swage tube with a crimping tool or pliers. Finally you can adjust the cable by loosening or tightening the cable connectors.

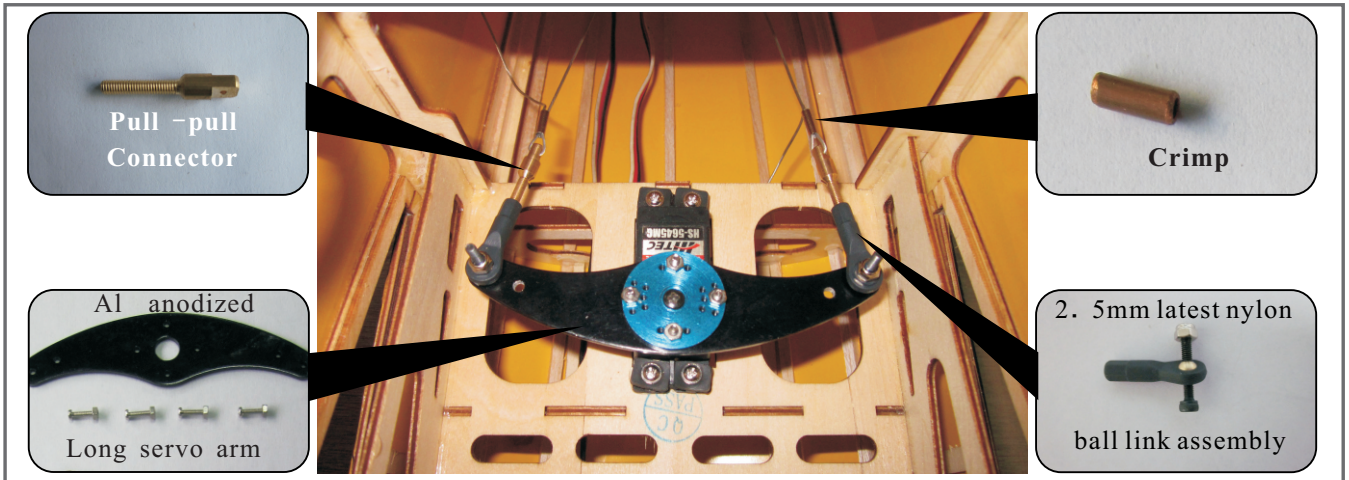

Tail Wheel Installation

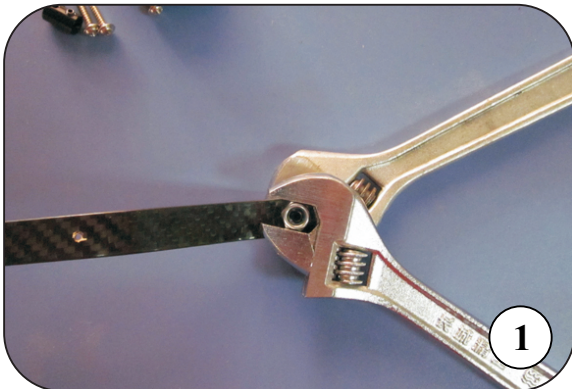
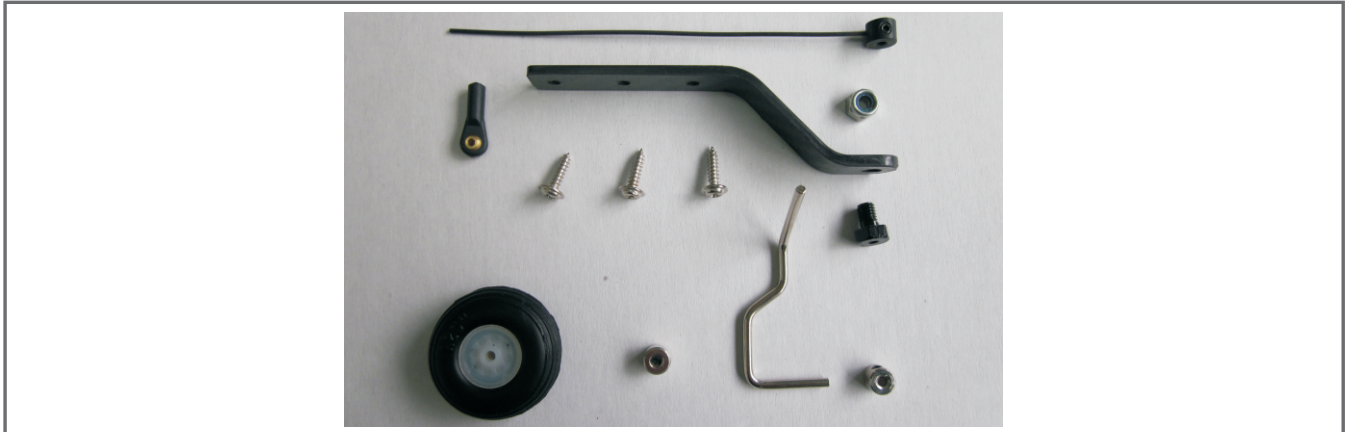

1. Install the carbon fiber tail wheel bracket with M5mm locking nut and M5 permanent seat AL screw.

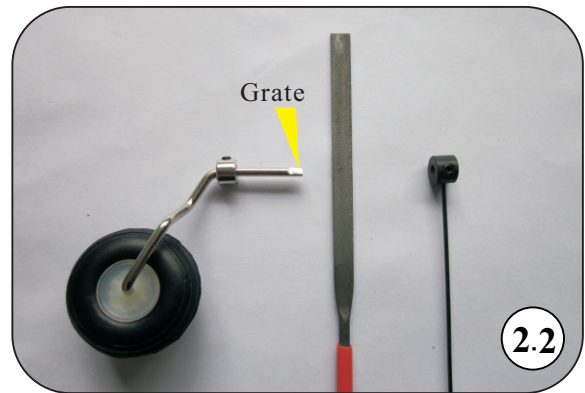
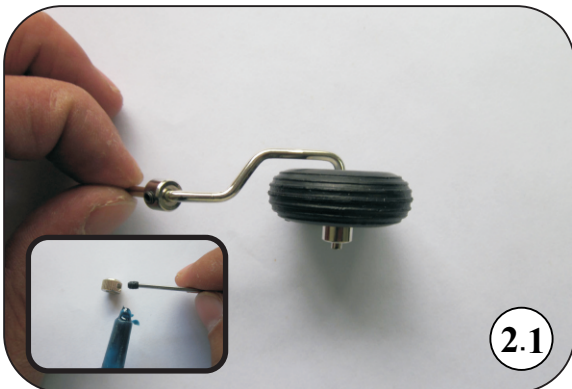

2. Install the wheel to the steel wire with wheel collars. All wheel collars should be secured with Blue Loctite. Grate the end of the steel wire with a grater.

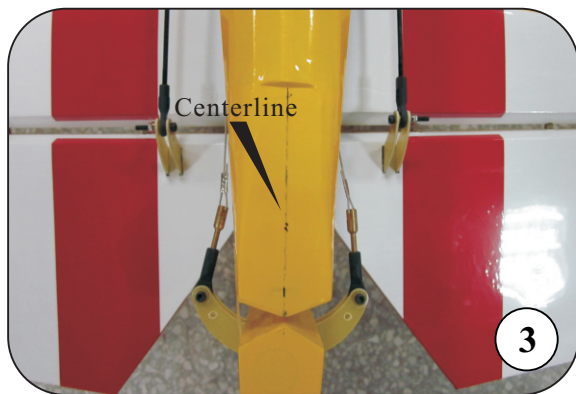

3. Draw a centerline on the fuselage tail with a pen.

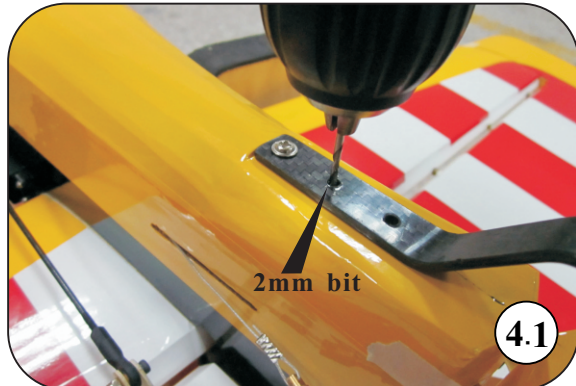

4. Use the tail wheel bracket as a template and drill 2mm holes. Install the tail wheel bracket with three M3*12mm tapping screws.

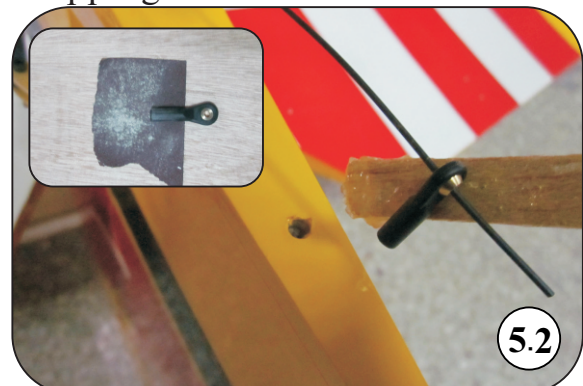
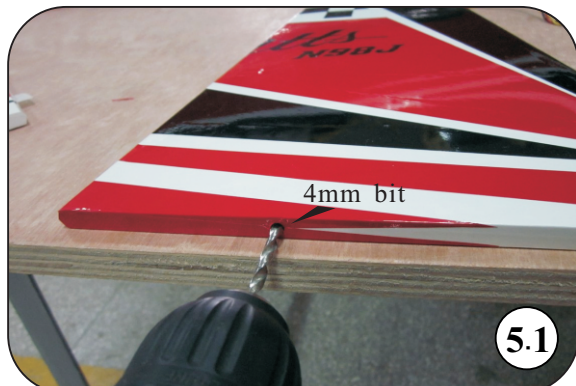

5. Drill 4mm holes in the bottom of the rudder. Scuffing the ball link with sand paper to ensure a good glue bond is suggested before gluing. Make sure the ball link hole is parallel to the rudder. Apply 30 minute epoxy inside the 6mm hole and coat the hinges with epoxy, Insert the ball link into the hole.

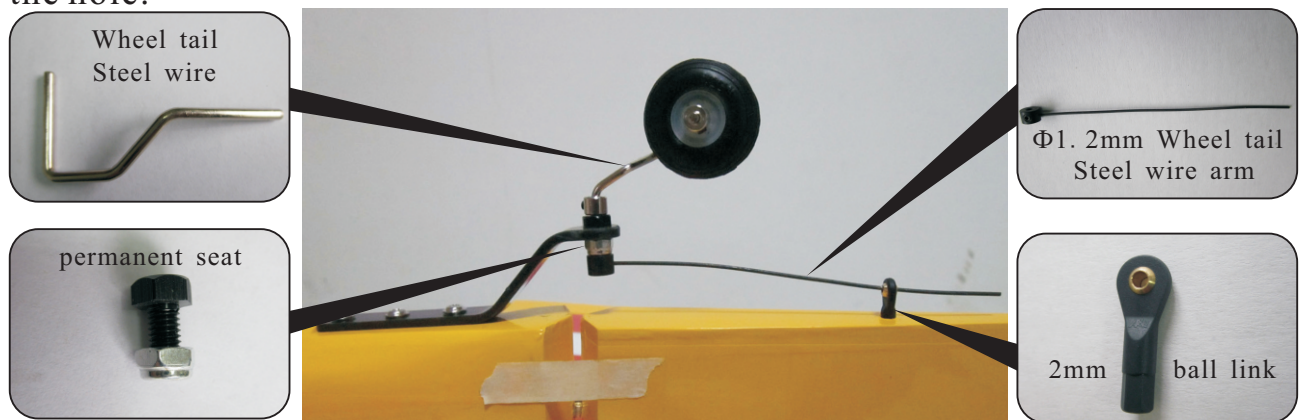

Fin And Stab Cable Tensioning

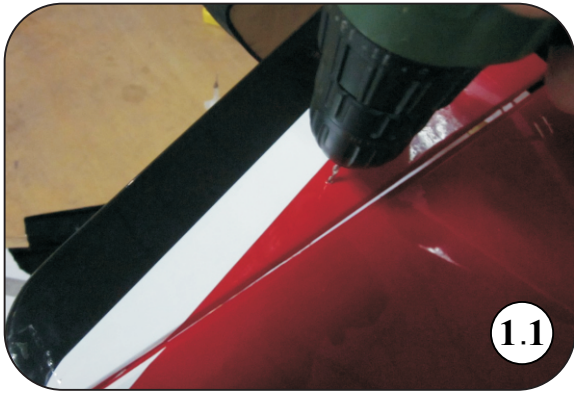

1. Find the hole mark on the fin and stab. Drill the 3MM holes.

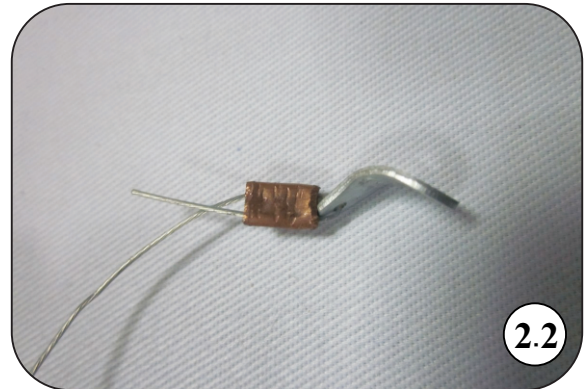
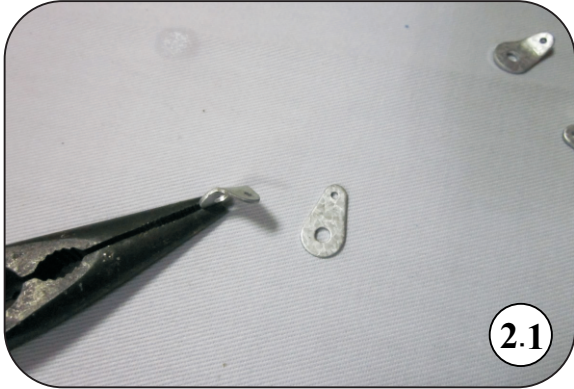

2. Bend the metal plate with a pliers.

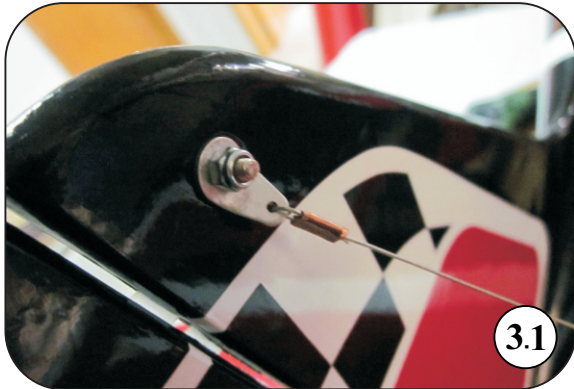

3. Check you have full elevator deflection before fasten the stab with cable.

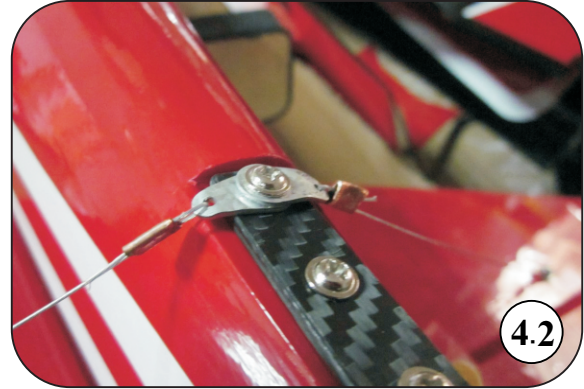

4. Fasten the cable to the stab and fin holes with screws and the brass swage tube.

Main Landing Gear Installation

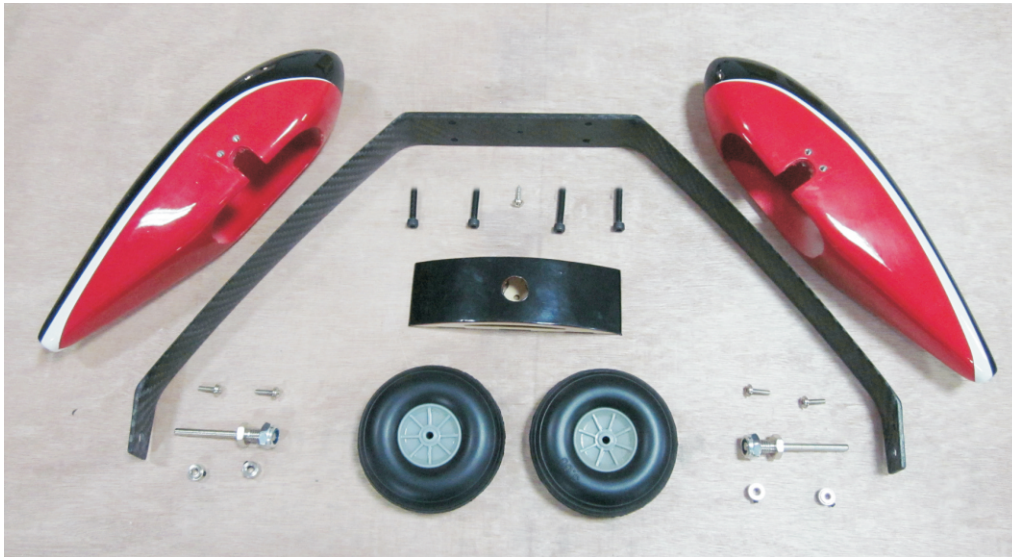

Landing Gear Installation

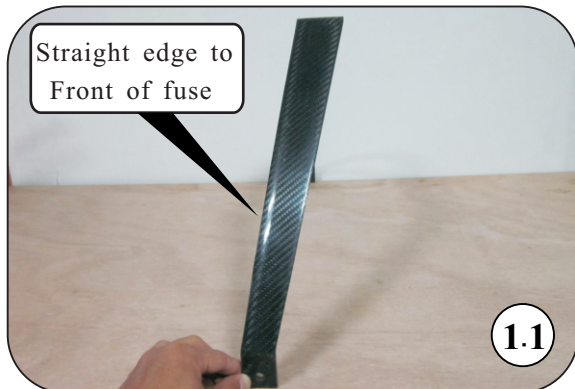

1. **NOTE: the correct edge in mounting.** Install the landing gear in the pre drilled holes with the supplied M4*25mm hex socket screws. All screws should be secured with Blue Loctite. Don't over tighten and crack the carbon fiber.



2. Remove the covering below to expose the holes with a knife and reinstall the landing gear hatch cover. Secure the M3*12mm tapping screw with a drop of CA. The hatch cover maybe not included in some planes.

Align axle screw with front of gear

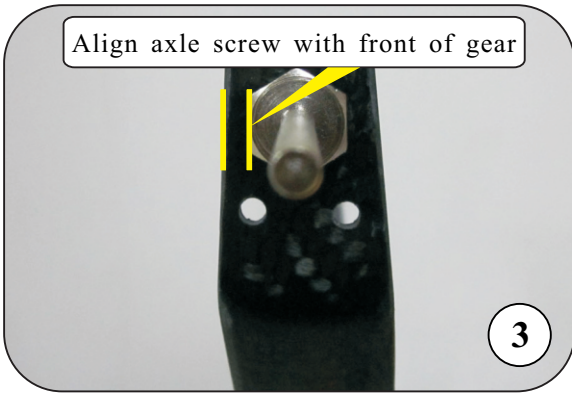

3. Tighten the M8 locking nut against the landing gear strut. (for some planes)

Pants Installation

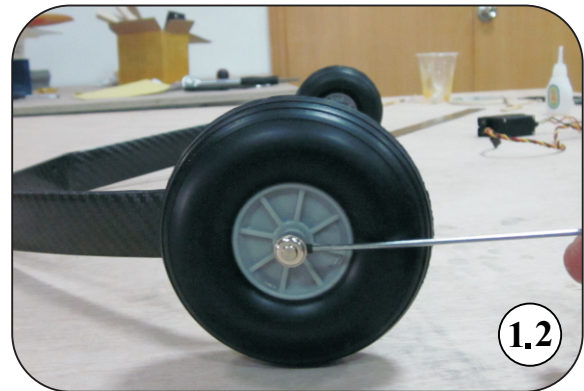
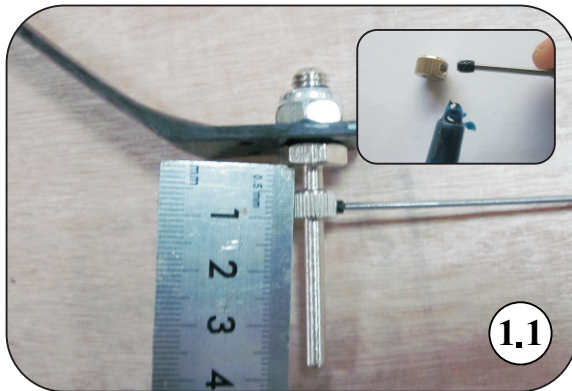

1. Install the inner wheel collar on the axle. screw and tighten the wheel collar in place. Adjust wheel collars in or out until wheel turns freely.

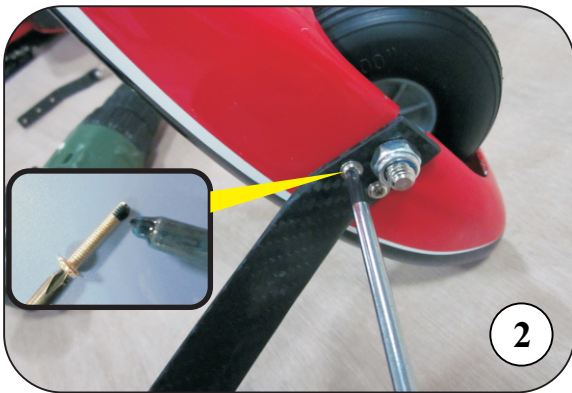

2. And then install the wheel pant with two M2. 5*12mm screws.

Engine Installation

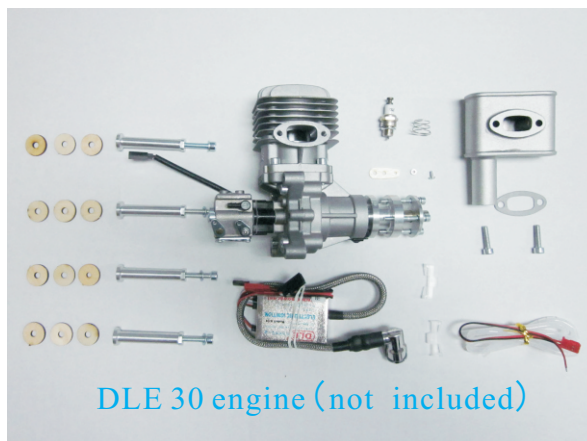

Firewall holes Assembly

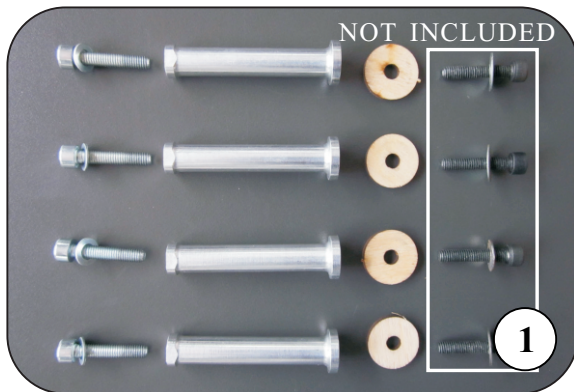

1. Do not use Blue Loctite on engine mounting screws until final assembly. The engine will need to be removed to fit the throttle pushrod and fuel line.

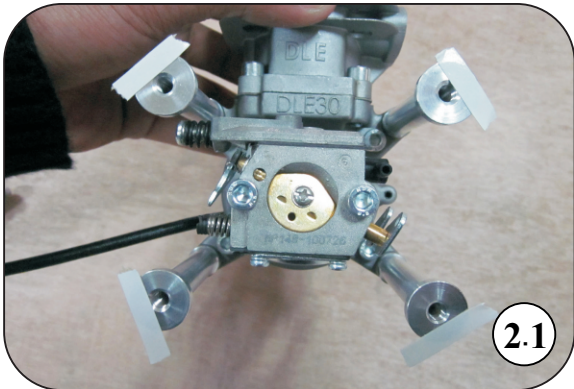

2. Tape a piece of 90*70mm paper to the side of the engine mounting with the double-sides tape. And stamp for the engine mounting on the paper with a pencil. Position the pushrod exit hole also.

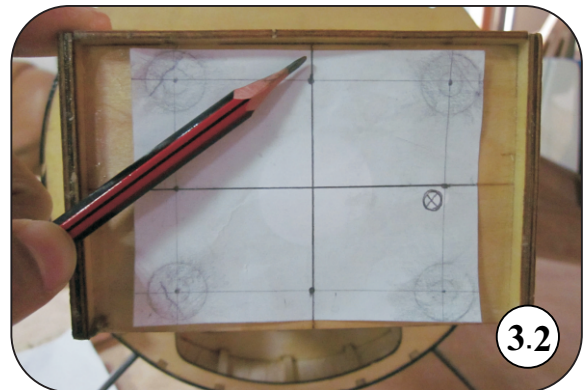
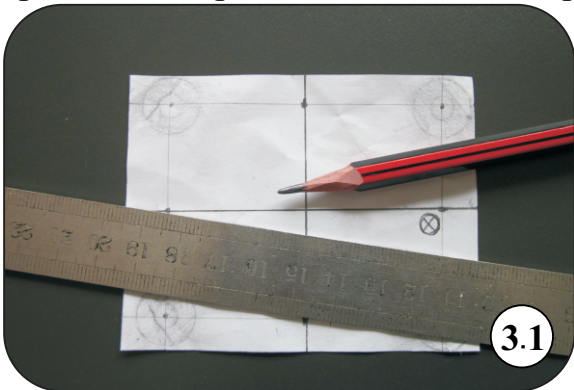

3. Draw the center-lines with a pencil as shown. Stick the template paper onto the firewall with the center-lines coincident.

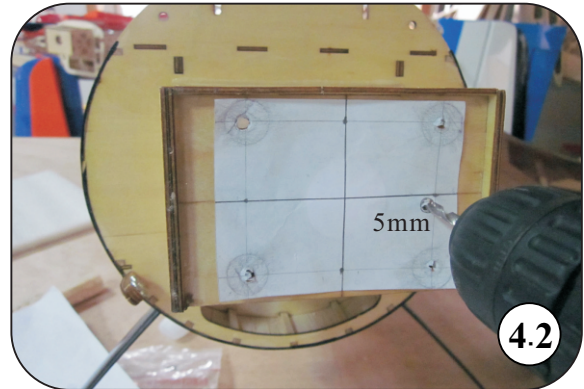
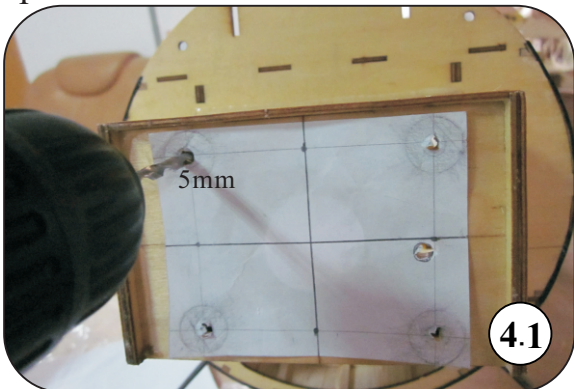

4. Drill four 5mm holes and a 5mm pushrod exit hole on the firewall.

Throttle Servo Installation

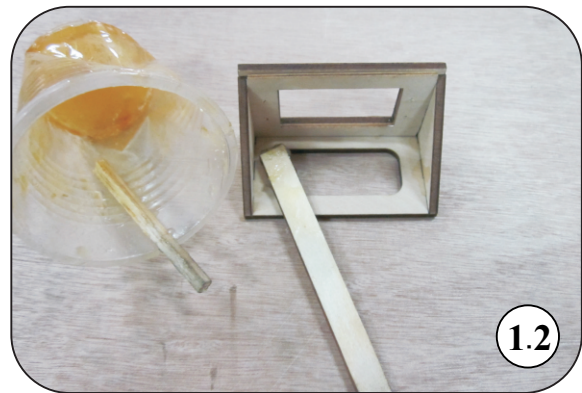
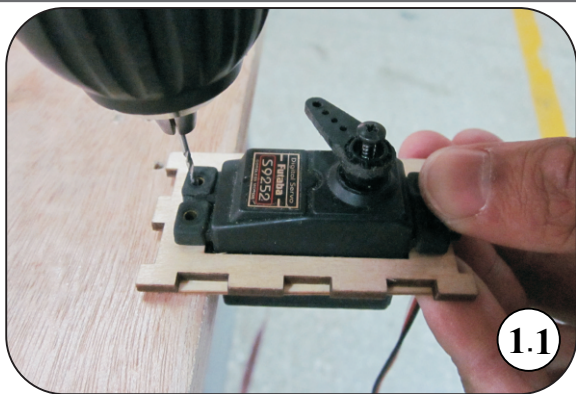

1. Drill 1mm holes in the throttle servo mounting and epoxy it.

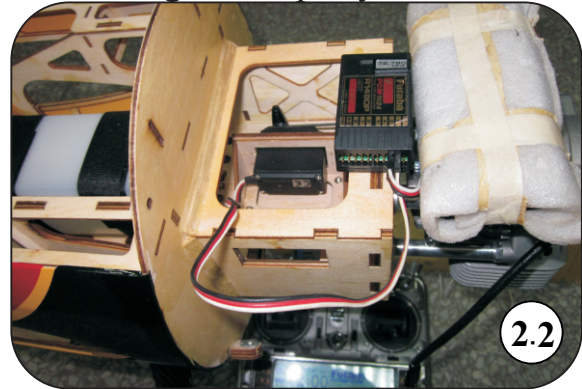
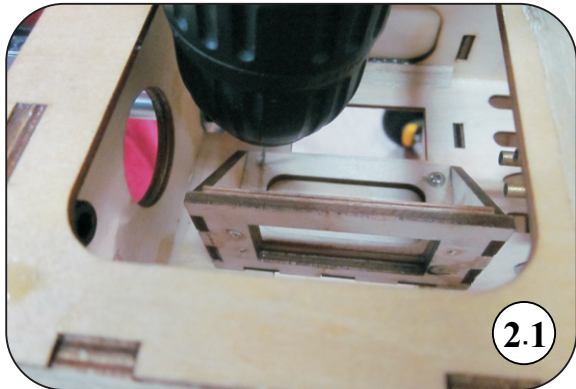

2. Mount the servo mounting with M2*12mm tapping screws or epoxy. Turn on the transmitter. And then install the arm on the servo. Position the servo arm 90 degrees to the servo.

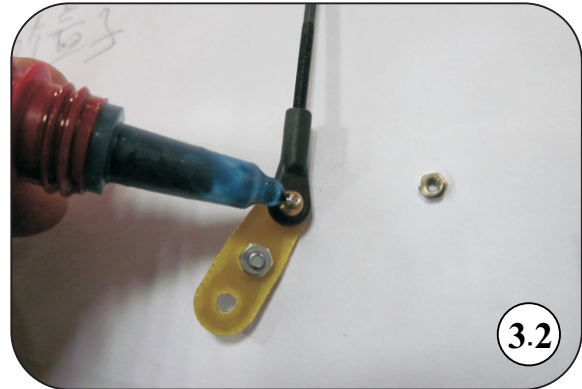
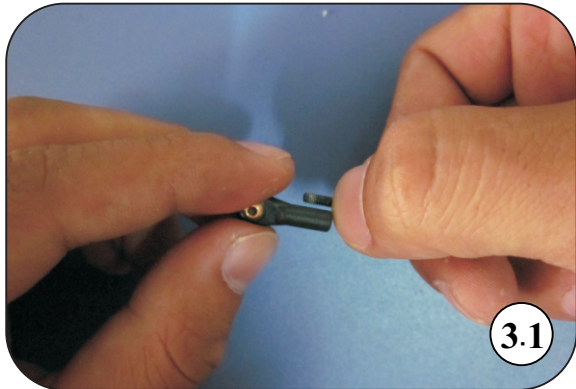

3 Thread the 2mm ball link half way onto the pushrod. Install the pushrod to the throttle arm with M2*8mm screws.

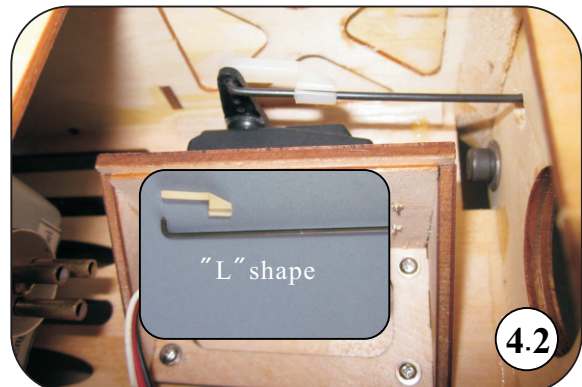
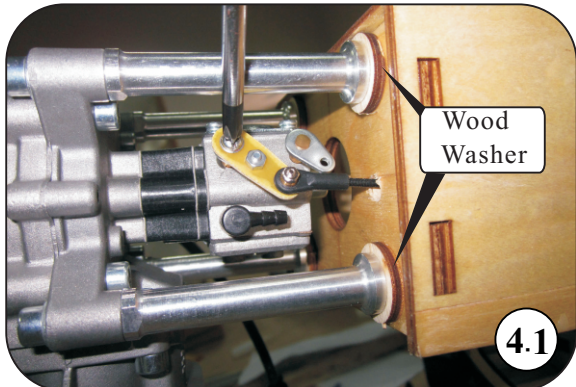

4. Remove pushrod from throttle arm on carburetor and cut throttle pushrod to length.. Use a L bend to connect the push rod to the servo arm.

Fuel Tank and Fuel line Assembly

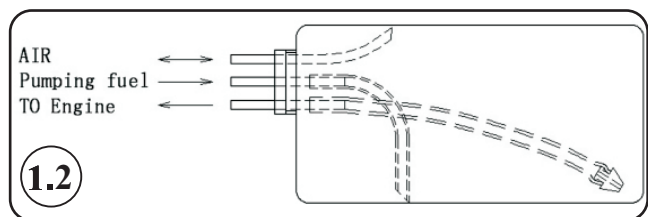

1. Fuel tube interface type has been originally marked.

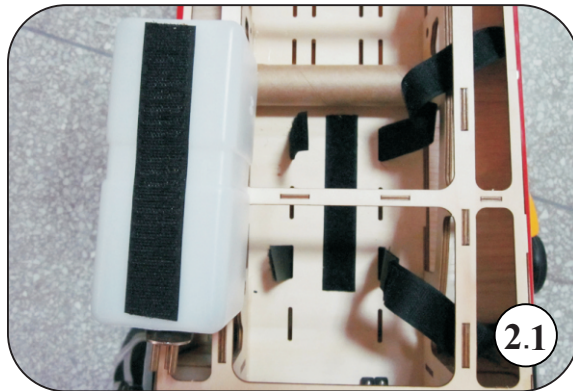

2. The tank bottom and cabin connect to the tank places had originally sticky connected to the VELCRO tie. Untie the velcro and install the fuel line on the copper pipe.

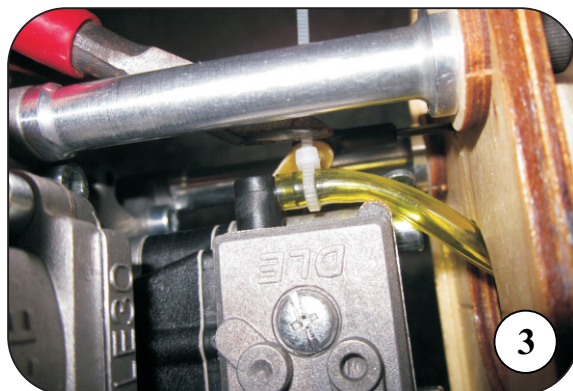

3. Install the engine fuel line to the carburetor tube. Tight the fuel line with nylon tie.



4. Drill a 6mm hole on the side of the fuselage. And then let 6mm pumping fuel line pass through the hole. Install the M5mm screw to seal the fuel line.

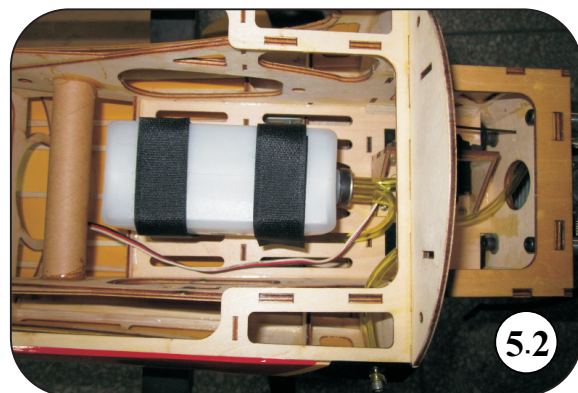

5. Drill a 6mm hole on the bottom of the fuselage. Let air line pass through the hole. Tightening the line with nylon tie will help to prevent lead from drawing back inside of fuselage during flying. Retight the tank with the velcro tie after the fuel lines are all right.

Ignition and the battery Assembly

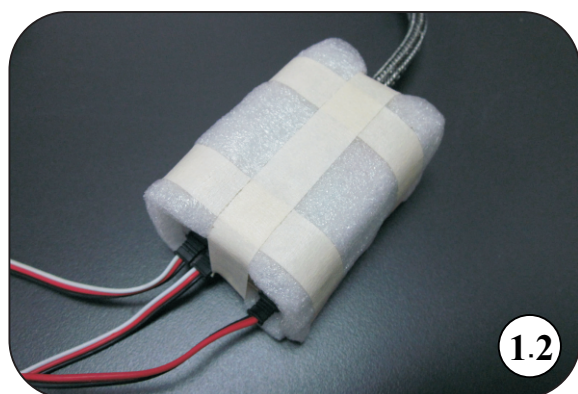
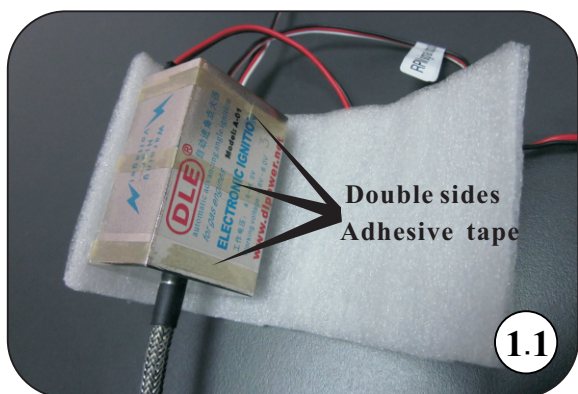

1. Trim a piece of foam rubber to the ignition module. Make the pad slightly larger than the ignition module. Bundle the ignition with tape as shown.

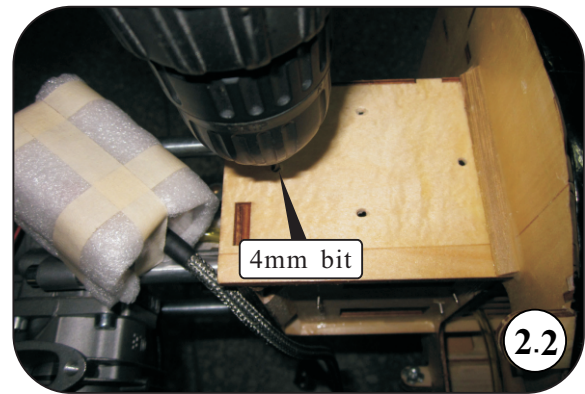
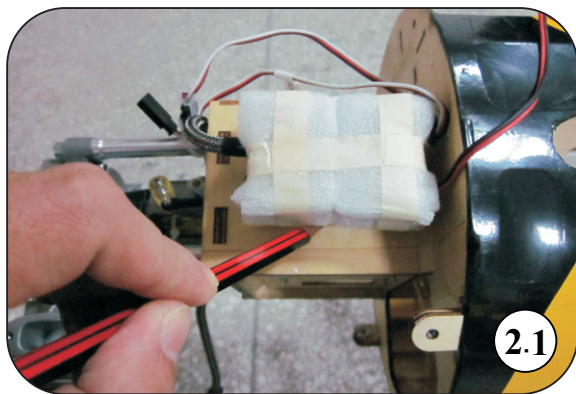

2. Position the ignition module on the side of the engine mounting box and mark the location of the nylon tie holes as shown. Use a 4mm bit to drill the ignition module mounting holes.

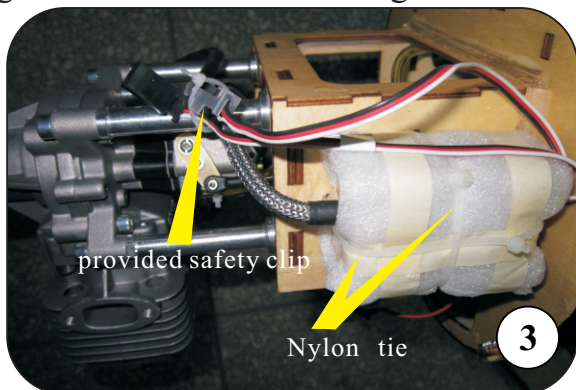

3. Thread nylon tie through mounting holes. Mount the engine ignition module using nylon tie as shown. Use the provided safety clips to secure the ignition and engine trigger line.

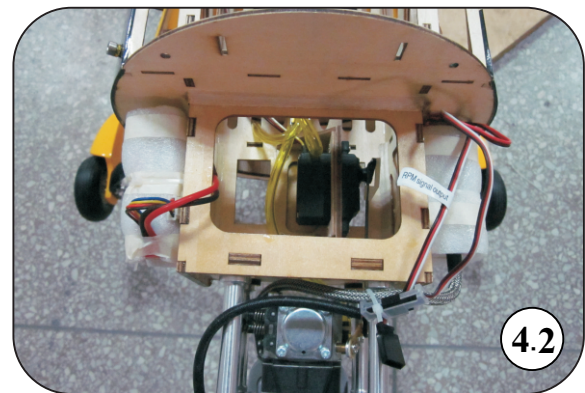
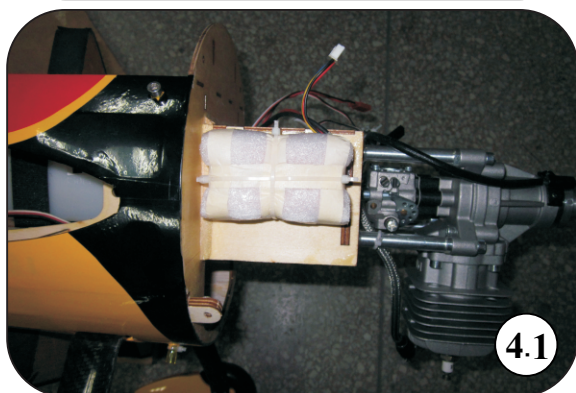

4. Repeat all the previous steps for the battery of ignition module.

Cowling Installation



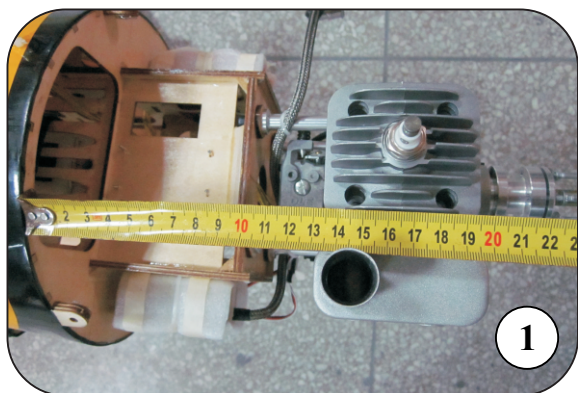

1. Measure the distance between the fuselage and the ignition plug (and exhaust) .



2. Measure the same distance on the cowling and mark it.



3. Use a rotary cutting tool and sanding drum to cut out the openings in the cowl. The shape and size of open pore depends on the type of the engine.



4. Install the cowl and check that everything fits correctly and nothing rubs against cowl. If needed enlarge the cutouts and test fit again until everything fits correctly.

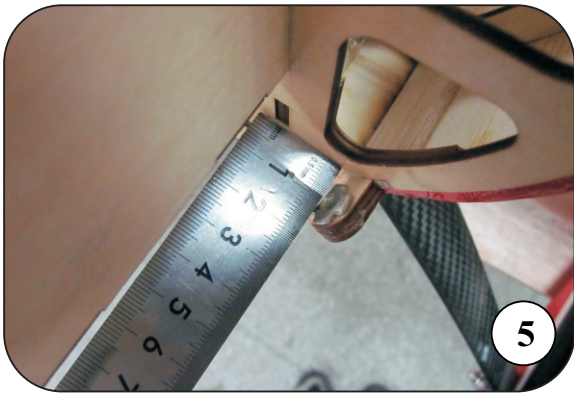

5. Measure the distance of the blind nut on the cowling and mark it.

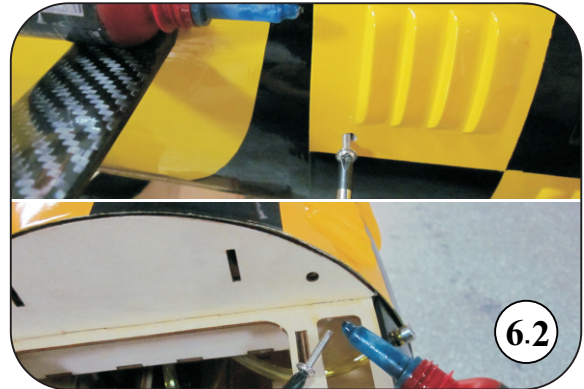

6. Drill two 4mm holes in place. And install the cowling with four M3*16mm screws with washers.

Wing Final Assembly

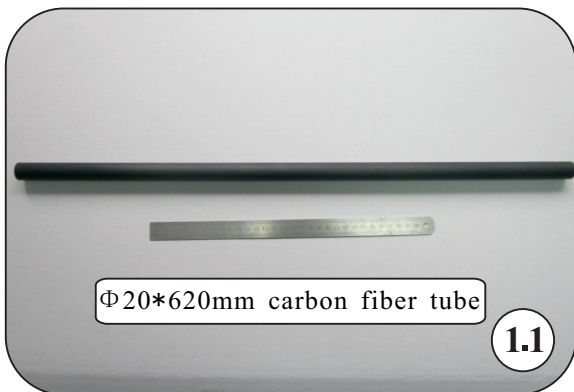

1. Slide the wing tube in the fuse wing tube sleeve.



2. Install the nylon bolts to the wing blind nuts. Tighten snugly but do not over tighten. Slide the wings on the wing tube and plug in the aileron servo connectors.

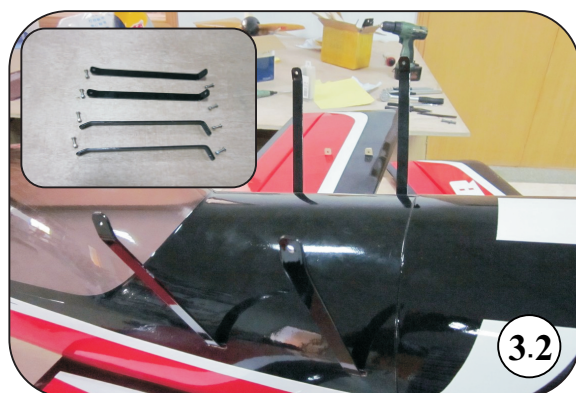

3. Install the AL wing bracing to the fuselage with M3*16 screws.

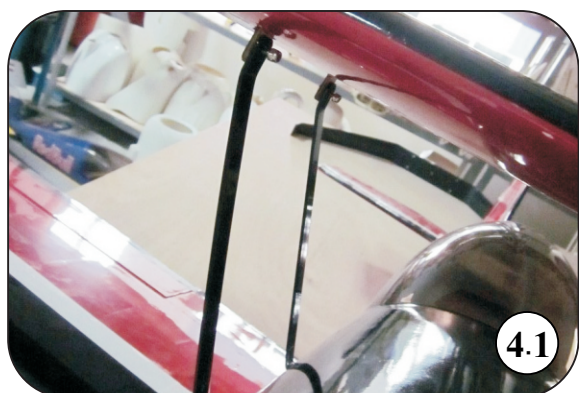

4. Install the upper wing with the wing bracing and locking nuts.

Canopy Assembly

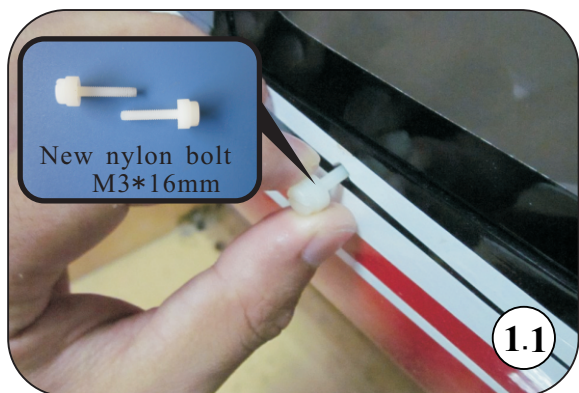

1. Install the canopy to the front of fuselage. Tighten the canopy with the M3*16mm nylon bolts.

Flight Preparation

C. G Location

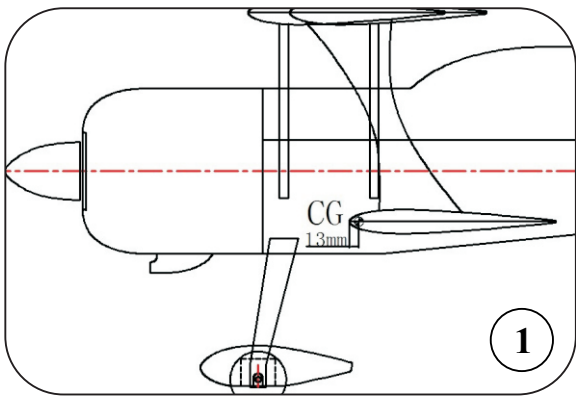

1. Measure the CG from the leading edge of under wing is 13MM.

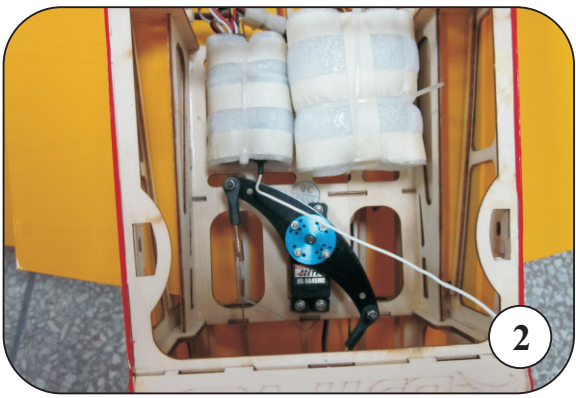

2. Adjust the battery location. The CG can be moved around to fit your personal taste.

Symmetry Control

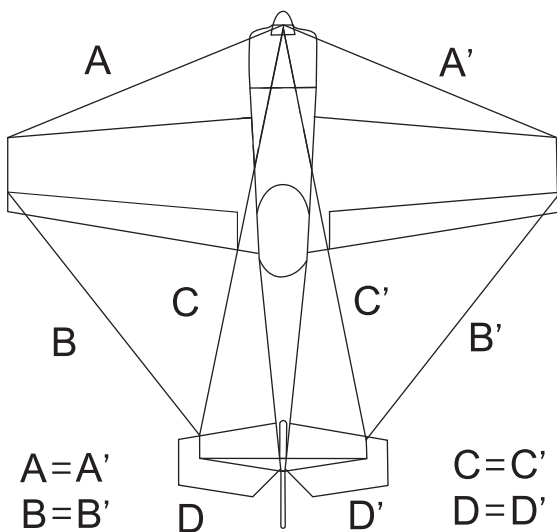

Adjust the aircraft and make sure both sides are symmetrical. Like the diagram shown. So that the plane is ready for flight.

Control Throws

	Surface	Throws	Exp
Common flying	Aileron	20 degrees	25%
	Elevator	20 degrees	25%
	Rudder	30 degrees	30%
3D flying	Aileron	45 degrees	50%
	Elevator	45 degrees	50%
	Rudder	45 degrees	50%

Engine Debugging

Trial run the engine to check its stability at high speed and low speed to ensure there are no problems with vibration on the model. Run the motor at high speed about 30 seconds. Check the engine and make sure the temperature is below the prescription of manufacturer.

Flight Checking

Check every angle and adjust them to correct position. Check all parts and make sure the installation is firm and reliable. Add some weight in either of wingtip to balance the left and right wings. Once everything is right.....

Good luck & Have fun!